



HEATING & COOLING COIL PRODUCTS



FV & FVH

FLOOR MOUNTED COOLERS

Capacities 28-150kW
White powder coated casing
Aerofoil fans
4, 6 or 8mm fin spacing
Vertical or horizontal
air discharge



HEATING & COOLING COIL PRODUCTS

The FV & FVH range of floor mounted coolers are designed to suit a wide range of cold storage, blast freezing, blast chilling, and food processing applications. The units are rigidly constructed with drawthrough aerofoil fans for efficient air throw and reliable performance. The coils can be offered for DX refrigeration or secondary refrigerants.



SPECIFICATION

Coil

Manufactured from 5/8 " o.d. copper tube mechanically expanded into heavy gauge aluminium plate fins will fully collared holes to ensure an efficient and permanent bond. Fin spacings 4 mm, 6 mm or 8 mm. Copper tube suction headers and distributors are individually sized to suit the exact operating conditions. Brazed joints are made with silver bearing copper alloy. Coils are pressure tested to 26 bar g, vacuum dehydrated and sealed with a dry nitrogen charge.

Casing

Galvanised sheet steel white polyester powder coated.

Fans

Axial flow, non overloading aerofoil fans with aluminium variable pitch blades secured into diecast aluminium hubs, keyed and locked onto the motor shaft. The fans run in a formed bell mouth orifice for efficiency and low noise.

Motors

Totally enclosed class F insulated metric frame, 380/420/3/50 Hz IP55.



DEFROST OPTIONS

Electric

For efficient defrosting low power density 200/250V 1 ph stainless steel sheathed elements are provided in the coil and draintray. Heaters are wired to a terminal box for 3 phase + neutral supply.

- ED 1** Light duty defrost for marginal room temperatures.
- ED 2** Normal duty defrost for low temperature applications.
- FP** Fan Peripheral Heaters - for horizontal air discharge applications with room temperature below zero.

Reverse Cycle / Hot gas

Coils may be circuited for reverse cycle or hot gas defrost with electric elements or hot gas tubes in the drain pan.

- HGE** Hot gas coil, electric drain tray
- HGD** Hot gas coil and tray
- RCE** Reverse cycle coil, electric tray
- RCD** Reverse cycle coil and tray

NOISE LEVELS

The noise levels stated are at a distance of 3 m from the unit at an angle of 45° to the horizontal in free field conditions with no reflections. These are intended to be used as a guide for comparison purposes. In practice the noise generated will be reflected off the enclosure surfaces and may be absorbed by the product within the room. For applications where noise levels are critical lower speed fans can be offered and the advice of an acoustic specialist is recommended.

AIR THROW

Cooler air throw is dependant upon coldstore design, product loading and positioning of coolers. Generally one metre space above product with no obstructions allows the air to travel considerable distances, providing that the room is tall and adequate space is allowed to return air at low level and velocity. Low head rooms need careful cooler siting and some means of separating discharge and return air. Cooler fans suck air back as well as blow.

OPTIONAL FEATURES



- Ducted Axial Fans
- Plain Galvanised Casing
- NS4 Marine Grade Aluminium Casing.
- Stainless Steel Casing
- Insulated Drain Pans
- Coils circuited for chilled water / glycol

SELECTION

Capacity tables are rated at - 8°C saturated suction temperature R22, 0°C air on temperature.

Capacities are net heat extracted by the coil not including fan heat.

Selection Example

A cooler is required to do 56 kW with R22 evaporating @ -30°C, room temperature - 23°C with 6 mm fin spacing and horizontal air discharge into a false ceiling for blast freezing. Heavy Duty Electric Defrost is required.

1. Select correction factor from table for 7 K TD and - 30°C evaporating.
2. Factor = 0.74
3. Correct required duty to catalogue rated capacity. $56 / 0.74 = 75.67$ kW
4. Select Model from capacity table. Model FVH1606 ED2.



FV & FVH CAPACITIES

Model	Capacity KW 8K TD	Coil Data				Capacity KW 8K TD	Coil Data			Air Vol m3/s	Fan Data					
		4 mm		6 mm			8 mm		No		Dia	120 Pa ESP			Air Throw Nom M	Noise Level dbA@ 3m
		Surface Area m2	Internal Volume dm3	Surface Area m2	Internal Volume dm3		Surface Area m2	Internal Volume dm3				rpm	kW	Nom FLC		
60	28.7	182	51.9	167	69.2	21.8	128	5.38	69.2	2	630	1400	1.1	2.9	30	80
70	33.5	212	60.5	194	80.7	25.4	150	6.28	80.7	2	630	1400	1.5	3.9	32	81
80	38.2	243	69.2	222	92.2	29.1	171	7.18	92.2	2	710	1400	1.5	3.9	35	82
90	43.0	273	77.8	250	103.8	32.7	192	8.07	103.8	2	710	1400	1.5	3.9	37	83
100	47.8	304	86.5	278	115.3	36.3	214	8.97	115.3	2	710	1400	2.2	5.3	40	83
120	57.3	364	103.8	333	138.4	43.6	257	10.77	138.4	3	710	1400	1.5	3.9	42	84
140	67.3	427	121.7	391	162.3	51.1	301	12.63	162.3	3	710	1400	2.2	5.3	45	85
160	76.5	486	138.3	444	184.4	58.1	342	14.35	184.4	3	710	1400	2.2	5.3	50	85
180	85.6	544	154.9	497	206.6	65.1	383	16.07	206.6	3	800	1400	3	6.9	55	86
200	97.9	622	177.1	569	236.1	74.4	438	18.37	236.1	3	800	1400	4	9.2	55	88
240	116.2	738	210.3	675	280.4	88.3	520	21.81	280.4	3	800	1400	4	9.2	60	88
280	133.9	851	242.3	778	323.1	101.8	599	25.14	323.1	4	800	1400	4	9.2	60	90
320	151.5	963	274.2	881	365.6	115.2	678	28.45	365.6	4	800	1400	4	9.2	60	90

Electric Defrost					
Model	Coil & Drain Pan kW				Fan Periphery kW
	4mm ED1	4mm ED2	6&8mm ED1	6&8mm ED2	
60	12.3	15.7	13.4	17.4	1.1
70	12.9	16.2	15.1	19.0	1.1
80	14.3	18.0	18.0	21.0	1.3
90	16.5	21.0	18.8	24.0	1.3
100	17.3	21.8	20.3	25.5	1.3
120	20.3	25.5	22.5	30.0	2.0
140	19.6	24.5	22.0	27.7	2.0
160	22.0	27.7	24.5	32.6	2.0
180	24.5	31.0	26.9	35.9	1.7
200	26.9	34.2	29.3	39.1	1.7
240	29.3	37.5	32.6	42.4	1.7
280	33.48	42.78	37.2	48.36	2.2
320	37.2	48.36	40.92	53.94	2.2

Total Fan Heat Input	
Model	kW
60	2.8
70	3.8
80	3.8
90	3.8
100	5.2
120	5.7
140	7.8
160	7.8
180	10.5
200	13.8
240	13.8
280	18.4
320	18.4

Capacity Correction Factors										
TD DT1	R22 Evaporating Temperature °C									
	-40	-35	-30	-23	-18	-12	-8	-7	-1	+ 5
6	0.57	0.60	0.64	0.66	0.70	0.72	0.75	0.76	0.79	0.8
7	0.67	0.70	0.74	0.77	0.81	0.84	0.88	0.88	0.92	0.9
8	0.76	0.80	0.85	0.88	0.93	0.96	1.00	1.01	1.05	1.1
9	0.86	0.90	0.96	0.99	1.05	1.08	1.13	1.14	1.18	1.2
10	0.95	1.00	1.06	1.10	1.16	1.20	1.25	1.26	1.31	1.4

FV & FVH DIMENSIONS AND WEIGHTS

Model	Dimensions										Weights kg			
	H1	H2	W	D	G	FH	FL	E Aerofoil	E Ducted Axial	F	8 & 6 mm		4 mm	
	Al Fins	Cu Fins	Al Fins	Cu Fins	Al Fins	Cu Fins	Al Fins	Cu Fins	Al Fins	Cu Fins	Al Fins	Cu Fins	Al Fins	Cu Fins
60	1615	2053	2390	1035	838	915	1930	100	360	920	430	523	412	517
70	1767	2285	2390	1035	918	1067	1930	100	435	1000	465	574	445	568
80	1513	2030	3355	1035	918	812	2895	100	435	1000	564	689	543	683
90	1615	2133	3355	1035	918	915	2895	100	435	1000	594	733	569	726
100	1716	2234	3355	1035	918	1016	2895	100	435	1000	620	776	594	769
120	1920	2438	3355	1035	918	1220	2895	100	435	1000	723	910	694	904
140	1818	2336	4165	1035	918	1117	3705	100	435	1090	824	1043	790	1036
160	1970	2578	4165	1135	1008	1270	3705	100	435	1090	901	1150	864	1144
180	2122	2730	4165	1135	1008	1422	3705	100	435	1090	929	1208	889	1202
200	2326	2934	4165	1135	1008	1626	3705	100	435	1090	995	1313	950	1308
240	2630	3238	4165	1135	1008	1930	3705	100	435	1090	1146	1524	1094	1519
280	2630	3238	4730	1135	1008	1930	4270	100	435	1090	1338	1774	1280	1770
320	2885	3483	4730	1135	1008	2185	4270	100	435	1090	1440	1932	1374	1928

Dimensions

Model
FVH

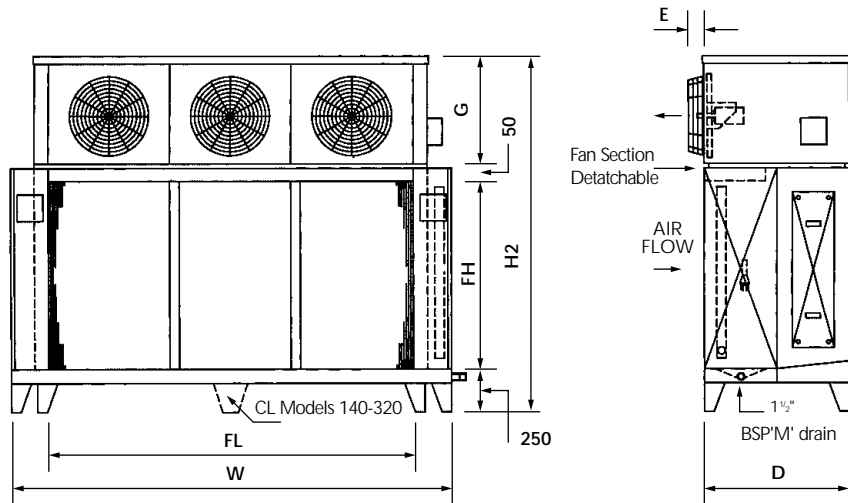

Model
FV

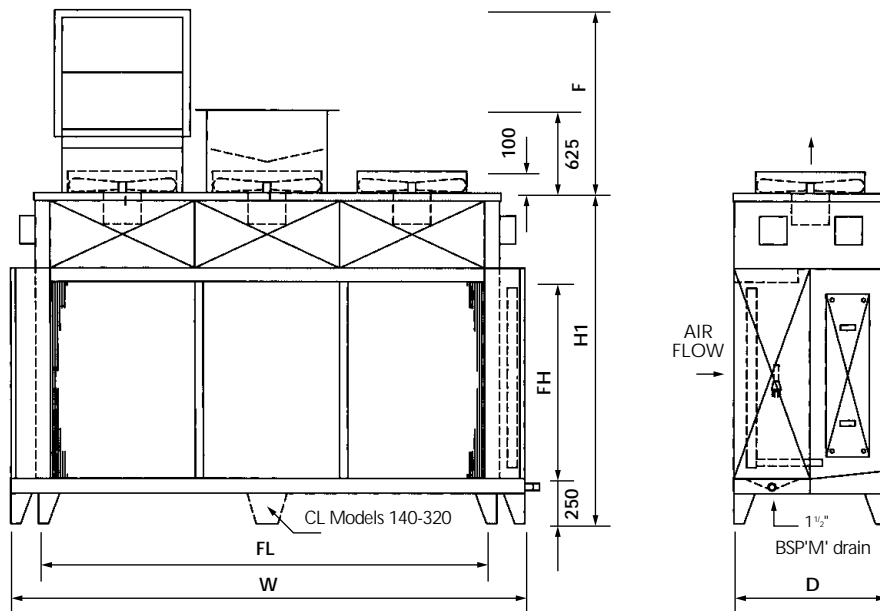

HOW TO ORDER.

FVH 160 4 ED2 PH AE CU/AL WP

Model FV or FVH

No

Fin spacing

Defrost

ED 1

ED 2

HGE

HGD

RCE

RCD

PH

Fans AE Standard Aerofoils
DA Shortcase Axial

Tube / Fin Material

Cu/Al Copper Tubes with Aluminium Fins

Cu/Al Copper Tubes with Polyester Coated
Aluminum Fins

Cu/Cu Copper Tubes with Copper Fins

Cu/Cu/Et Copper Tubes with Copper Fins Electrotinned

Casing

WP White Powder Coated Galvanised Sheet Steel

PG Plain Galvanised Sheet Steel

ST T304 Watch Case Stainless Steel

AL NS4 Marine Grade Aluminium

Cowls Fan Cowls

Dampers Butterfly Duct Dampers

Ducts Ducts to x m o/a height

When ordering we need to know the following:

Evaporator Duty

Refrigerant

Evaporating Temperature

Room Temperature

Liquid temperature before TEV.

Connection Handling - looking at coil face (LACF)

HEATING & COOLING COIL PRODUCTS LTD.

Unit 21 Wingate Road, Fort Brockhurst Ind Estate,
Gosport, Hampshire, PO12 4DR

Tel: 02392 501431. Fax: 02392 529272

E-mail: sales@handccoils.co.uk WEB: www.handccoils.co.uk



Bulletin FV,FVH 1/3/07

We reserve the right to change in whole, or in part, the specification detailed in this brochure without prior notice, and when necessary, to achieve continuous production, to use alternative competitive designs of sub contract components made by various manufacturers.